

# The Navigator

The Newsletter of Alamo Squadron

*The San Antonio chapter of the International Plastic Modelers' Society  
A registered 501c-7*



May 2018

IPMS/USA Chapter of the Year:

1998-1999 & 2004-2005

IPMS/USA Regional Chapter of the Year: 2016

## WEATHER AN EAGLE

### HOW TO GET YOUR EAGLE TO LOOK LIKE IT'S BEEN TO THE MOON AND BACK



TAKE A RIDE  
WITH DICK IN THE  
BLAZO SQUADRON  
TIME MACHINE  
TO THE EARLY SEVENTIES

CRAIG PUTS A  
NICE TOUCH TO A  
SIMPLE KIT



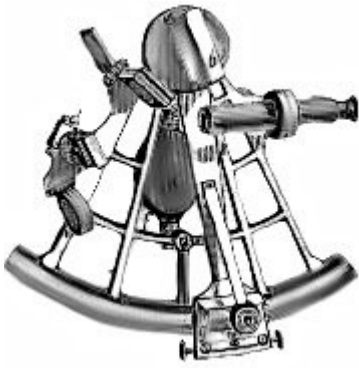

# President's Column

By Herb Scranton III

IPMS #48314



## President's Message - May 2018

As your new President I would like to thank our members for their support by electing me as the new president of the club, but just as important by electing Jose Valdenegro as Vice President and Dana Mathis as Treasurer. What a great team for success. Without Dick Montgomery's arm twisting, I mean guidance I would not have been the Vice President and I assure you I have provided the same arm twisting, I mean encouragement to Jose. I would like to thank Len Pilhofer and Dana Mathis for the outstanding leadership over the past year.

Congratulations are in order; because of the efforts of Craig Gregory and Len Pilhofer the "Alamo Squadron Newsletter" and Website has been awarded the IPMS Region VI newsletter and website of the Year.

I am looking forward to serving you this year. We have Model Fiesta planning to start up soon, and hopefully the IPMS Nationals in 2020. The monthly modeling classes are great and I encourage all of our members to participate, we all have something to offer to improve our skills. The WIP table is always full which just goes to show we are a builders club and not just a social gathering, keep up the good work.

As your President this is my plan for the upcoming year. We are a model building club and I want to encourage our members to build. Enter your models in the monthly contest, show your stuff. Teach a class. I think it is the best way to keep new and old builders engaged. Show us the newest model on the shelf you can't wait to build. Write an article for the newsletter. I'm sure after your read this you will realize anyone can write something in the newsletter. Just a short funny story about modeling, have I told you about the

1978 Pinto I started in 1978 and just finished last month. It only took 40 years. I have some other ideas that I will be discussing at my first EB meeting. As your president I will give at least one class this upcoming year and will try to have something on the WIP or Contest table every month. The business of our club is important but, I will try to keep the business part of the meetings short. Just one more thing, this is a hobby, not a job, let's have some fun and enjoy the trip.



Alamo Squadron's Newest and Youngest Member.  
Adam Blackmon sports his most recent build

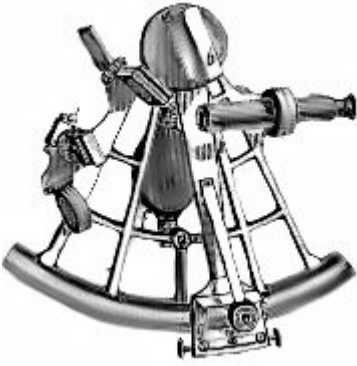

# Club Announcements

---

## Newsletter & Website of the Year

Alamo Squadron has been named the **Region VI Newsletter and Website of the Year or 2017**. Thank you to all who contributed, especially to The Navigator, to make this an award winning publication. Now on to the national competition with results being announced at IPMS Nationals this summer.

## IPMS National Convention 2018: Build It, Bring It, Show It!

May 1st means we are exactly 3 months away from the **2018 IPMS/USA National Convention**, this year hosted by our good friends in Phoenix. There has been discussion about this Nats at previous meetings as logistical plans are being made by several members to attend this year's big show. If you are interested in attending please get with Len and he can help you work your plans for a successful visit. Be sure to check out the site: [www.ipmsusanationals2018.org](http://www.ipmsusanationals2018.org) to take care of several items: reserve your hotel room, purchase your banquet tickets, and register for the convention. Remember, in order to participate in the contest - with unlimited model entries free with registration - you have to be a *current* IPMS/USA member.

## Kit of the Month

Each month a member will bring one of their recent acquisitions and open it to let others peek inside the box. With a few brief comments and few questions answered, we will get to know what's in the box and if we will rush home to order a copy. When you are ready to present, contact and coordinate with Craig Gregory: [craig.jonathan.gregory@gmail.com](mailto:craig.jonathan.gregory@gmail.com).

## Alamo Squadron Build Days

We are officially retiring the "Bachelor Build Nights" for the foreseeable future but replacing them with "**Build Days**". Alamo Squadron has secured the Hobby Town Community Room on the first Saturday of each month for the rest of 2018. We will hold the build day from 12:00-4:00PM on each of these Saturdays. The intent of these build days is to move more of the social and building aspect of our meetings to a more conducive environment...and what better environment than a hobby store! There will be no set format but if a member wishes to see a first hand demo on a certain technique then this is the perfect opportunity to make it happen. We hope that many club members will take the opportunity to participate. And added bonus is that we will be able to recruit for Alamo Squadron while at this establishment answering any and all question of passers-by.

## Monthly Contest Schedule

May	<b>May the Fourth Be With You</b>
June	Open
July	Open
<b>August</b>	<b>The Color White</b>
September	Open
October	Open
<b>November</b>	<b>Out of Your Element</b>

## Web Page Bios

This is a way for members to learn a little bit of modeling-related information of their club mates in order to facilitate the sharing of knowledge and techniques in modeling genres and areas. In no way is this mandatory and only if you wish to share your info with other club members should you participate. If you wish to have your bio published please reach out to Len at [pilhofer@hotmail.com](mailto:pilhofer@hotmail.com). Here is a link to the bios already on the site: [alamosquadron.com/members.html](http://alamosquadron.com/members.html).

# Club Announcements

## April Club Contest Results



First Place:  
Eduard 1/48 F6F-k Drone  
Kent Knebel



Second Place:  
MPC 1978 Pinto Cruisin'  
Wagon  
Herb Scranton III



Third Place:  
1/72 Me-109H & Blohm Und Voss (V1)  
Lee Forbes



# Kit of the Month

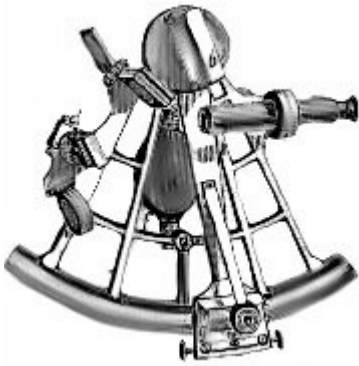

## Bandai Perfect Grade Millennium Falcon

Presented by Len Pilhofer  
IPMS #49932



In celebration of Star Wars day—the 4th of May—this month’s feature kit is the recent release of the iconic Millennium Falcon from the Star Wars movie franchise. This is arguably the most famous ship—almost a character itself—in the entire science fiction genre. And one, that I might add, is one of my personal favorites ever since I first saw it on the big screen as a kid in 1977.

This Perfect Grade kit from Bandai is a “no holds barred” version of the famous Corellian Freighter. 39 years ago MPC released the first version of the Millennium Falcon in 1/78 scale. This one was not bad for its time and it continued life as an AMT release for many years after that and into the 1980s. It was not until Fine Molds from Japan released a much improved version in 1/72 in 2006 that the bar was raised in quality. That kit, now out of production is sought by many collectors. Luckily, when Revell was awarded the Star Wars merchandising license from Disney in 2014 the Fine Molds kit was released shortly thereafter under it’s new Revell label—although in this author’s opinion not as nice a package as the original Fine Molds 2006 release. Now, we have the Bandai version available to all modelers, albeit a tad pricey. My counter to this complaint is that this is one extremely well done kit.

This version of the Falcon is from Star Wars Episode IV, A New Hope. It has the tricycle landing gear as seen in the first movie. In later movies the special effects model building team added two more landing gear legs for a total of five legs - four main legs and a nose leg.

At the May Alamo Squadron meeting I will have this kit on display for all to see and determine for themselves the quality of the kit. I’m sure most will agree that it is a step above all others and well worth the money.



Subject: Millennium Falcon

Manufacturer: Bandai

Product / Stock #: 0216384

Scale: 1/72

List Price: \$399.99

Web Site: <http://www.bandaionline.com/perfect-grade-1-72-millennium-falcon-plastic-model-in-stock/>

# Cover Story

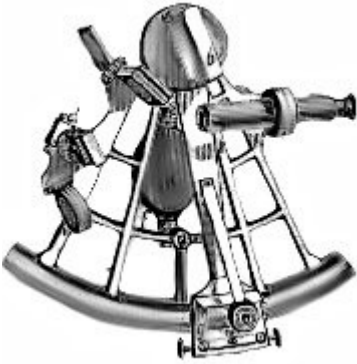

## Weathering The Eagle

Model, Photos, and Story by Len Pilhofer  
IPMS#49932



One of my favorite shows on TV as a kid was Space: 1999. Produced in the UK and running only 2 seasons from 1975-1977 it eventually aired in syndication in the US at various local stations around the country. Many had not seen the show when it aired but I was lucky enough to live in a city that carried it.

One of the most nostalgic aspects of the show is the main spacecraft of this science fiction series: the Eagle Transporter. It's primary designer, Brian Johnson had done earlier work on the iconic film: 2001: A Space Odyssey. His work from that film can be seen in this famous ship from the British TV series

In 2015 Round Two models released the largest kit of this subject to date. It is a 1/48 scale version of the Eagle and at this scale it comes in at 22"...quite an impressive size.



When I posted pics of my completed build to the Facebook group "Space:1999 Props & Ships" it received many positive comments. These comments focused primarily on the finishing and weathering techniques that I used. I decided to make some images/figures that spelled out my technique and shared them on this group. I now want to share them with you all here in the Navigator.

Tamiya X-1 (Black) is applied to all the corners, crevices, and "low" areas of the build.

The entire kit is primed with Tamiya Gray primer. Gray gives it a neutral base color from which the black and white pre-shading creates contrast. I utilized the Tamiya primer from the rattle can for this initial step.

Tamiya X-2 (White) is applied to all the higher areas and centers of panels.

These highlights and lowlights are applied with an Iwata HP-B Plus with the paint thinned to about 50-50 with Tamiya Lacquer Thinner.

Len Pilhofer  
IPMS/USA Alamo Squadron

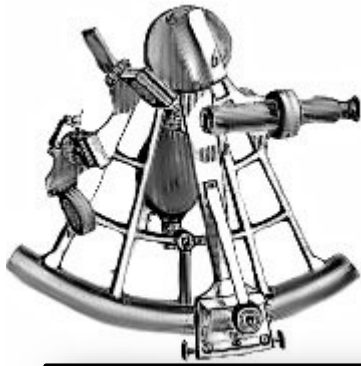

# Cover Story

---

## Weathering The Eagle

Next step is the base coat which is Tamiya X-2 (White) mixed with just a touch of X-1 (Black) to give it an off-white appearance. This coat is sprayed with an Iwata RG-3L Baby Airgun which gives a nice, wide coverage. I went with about 80% opacity in order for the pre-shading to show through and give maximum effect. Again, the paint is thinned to about 50-50 with Tamiya Lacquer Thinner.



After the base coat cured I masked-off the areas that were to be painted light gray. This gray is a darker mix of the X-2 plus X-1. For this job I utilized my main airbrush, a gravity-fed Iwata Eclipse. Paint is also thinned 50-50 with Tamiya Lacquer.



Len Pilhofer  
IPMS/USA Alamo Squadron

I wanted to go with the "Rescue Pod" version because of its highly contrasting, and eye-catching, colors. I masked-off the white base coat with Tamiya tape. There were areas where the tape ripped due to being pressed down into crevices so I applied Vallejo liquid mask to those areas. I then airbrushed a coat of Vallejo Satin Varnish to seal the tape and prevent leakage underneath.



Len Pilhofer  
IPMS/USA Alamo Squadron



# Cover Story

---

## Weathering The Eagle



I re-applied the black and white preshading to the areas where the red was going to be applied. I then airbrushed Tamiya X-7 (Red) thinned 50-50 with Tamiya Lacquer Thinner using the Iwata RG-3L. I applied light coats from at least a foot away. This helps prevent the paint from being forced under the tape from air pressure. It is a long process. The picture here is about 30 minutes worth of airbrushing. You can see the effects of the pre-shading, especially in the recessed, dark areas.

Len Pilhofer  
IPMS/USA Alamo Squadron

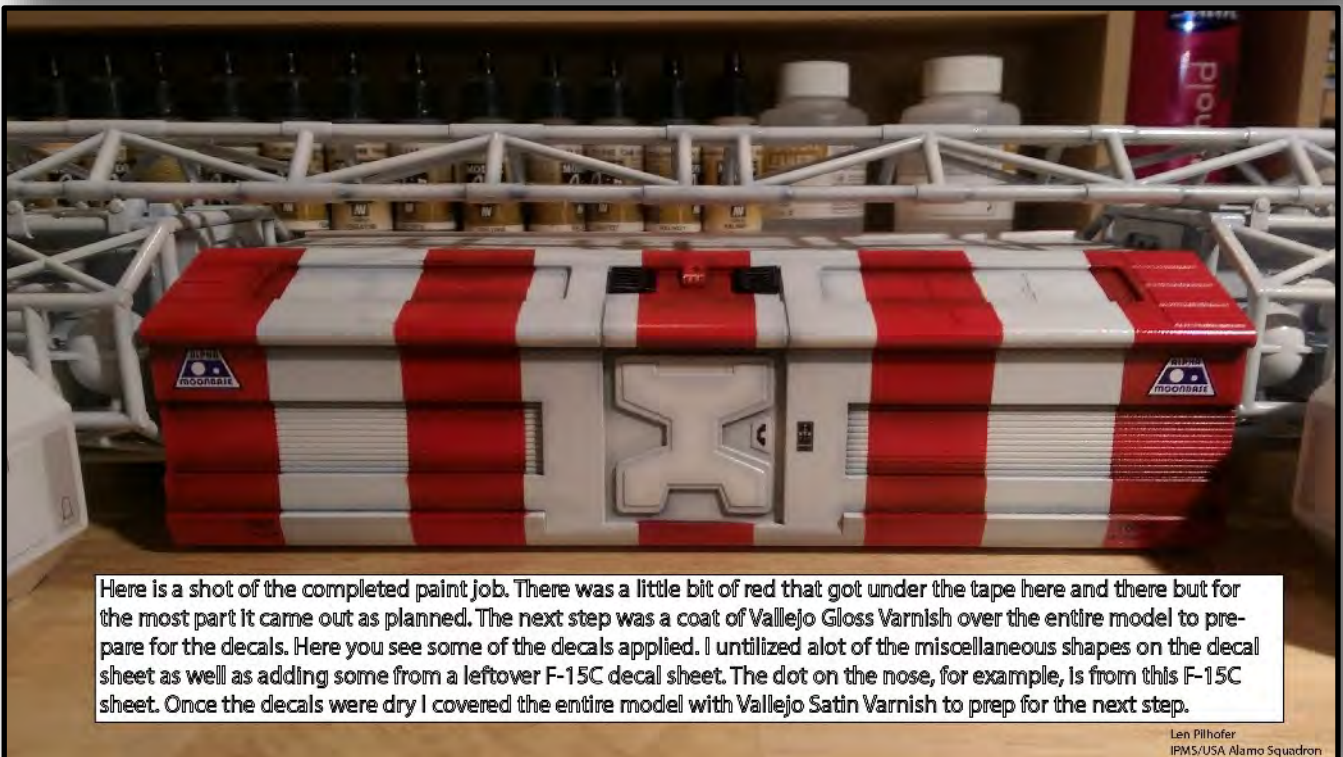

Here is a shot of the completed paint job. There was a little bit of red that got under the tape here and there but for the most part it came out as planned. The next step was a coat of Vallejo Gloss Varnish over the entire model to prepare for the decals. Here you see some of the decals applied. I utilized a lot of the miscellaneous shapes on the decal sheet as well as adding some from a leftover F-15C decal sheet. The dot on the nose, for example, is from this F-15C sheet. Once the decals were dry I covered the entire model with Vallejo Satin Varnish to prep for the next step.

Len Pilhofer  
IPMS/USA Alamo Squadron



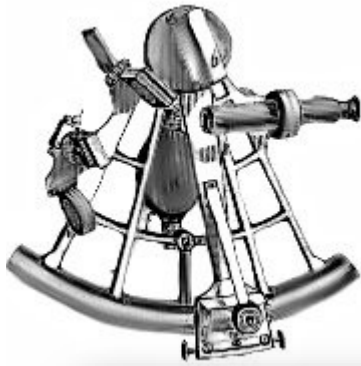

# Cover Story

---

## Weathering The Eagle

Len Pilhofer  
IPMS/USA Alamo Squadron



Here is another shot of all the decals in-place and ready for the next steps: a coat of Vallejo Satin Varnish and then the oil pin wash. For pin washes I utilize thinned artist oils. My favorites currently on the market are the Abteilung 502 brand. Here I utilized the "Starship Filth" color for the wash...very appropriate for this build. This wash is applied to every corner and crevice on the ship. It is cleaned up from unwanted areas with a clean brush lightly soaked in thinner. The brush is continually kept clean or else you will just be pushing oil paint around the surface of the model, not lifting it off. The goal is to leave the thinned oil paint only in the corners and crevices. Unlike acrylics the oils have to be left alone for a couple of days to allow for drying. Oil paint never fully cures but it should be dry to the touch. Another coat of Vallejo Satin Varnish is then applied over the entire model.

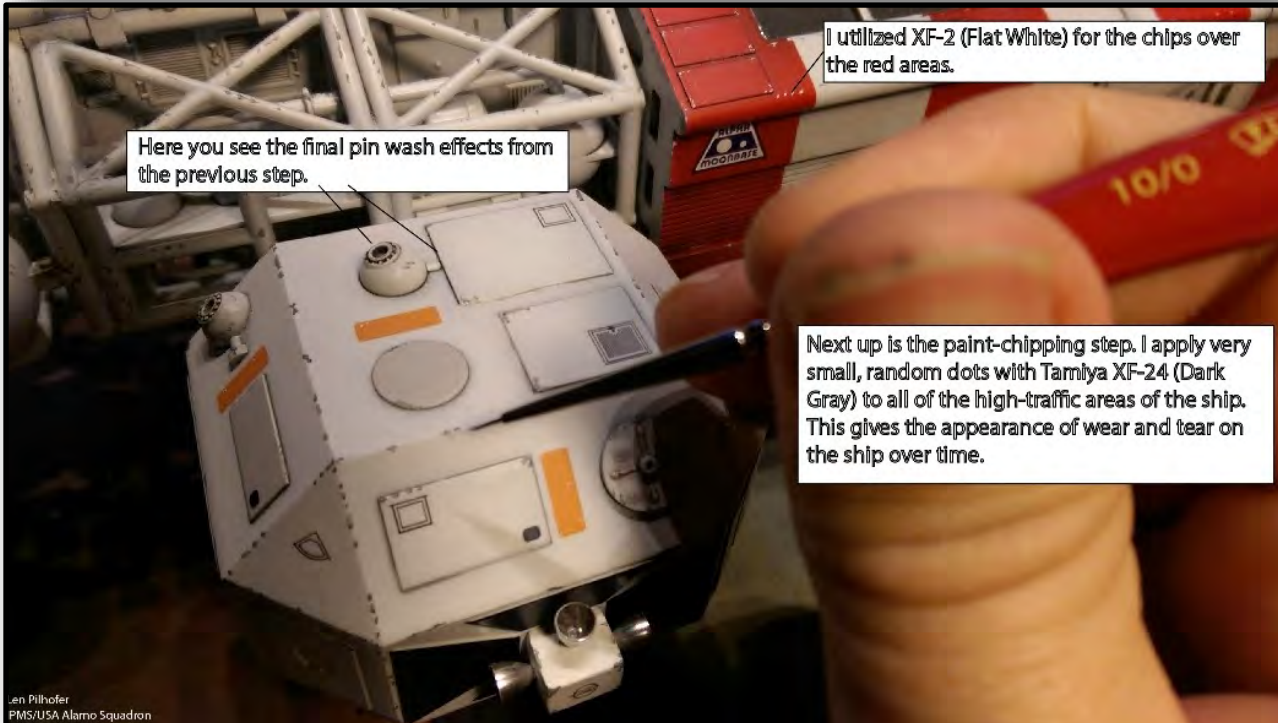

Here you see the final pin wash effects from the previous step.

I utilized XF-2 (Flat White) for the chips over the red areas.

Next up is the paint-chipping step. I apply very small, random dots with Tamaya XF-24 (Dark Gray) to all of the high-traffic areas of the ship. This gives the appearance of wear and tear on the ship over time.

Len Pilhofer  
IPMS/USA Alamo Squadron



# Cover Story

---

## Weathering The Eagle

Len Pilhofer  
IPMS/USA Alamo Squadron

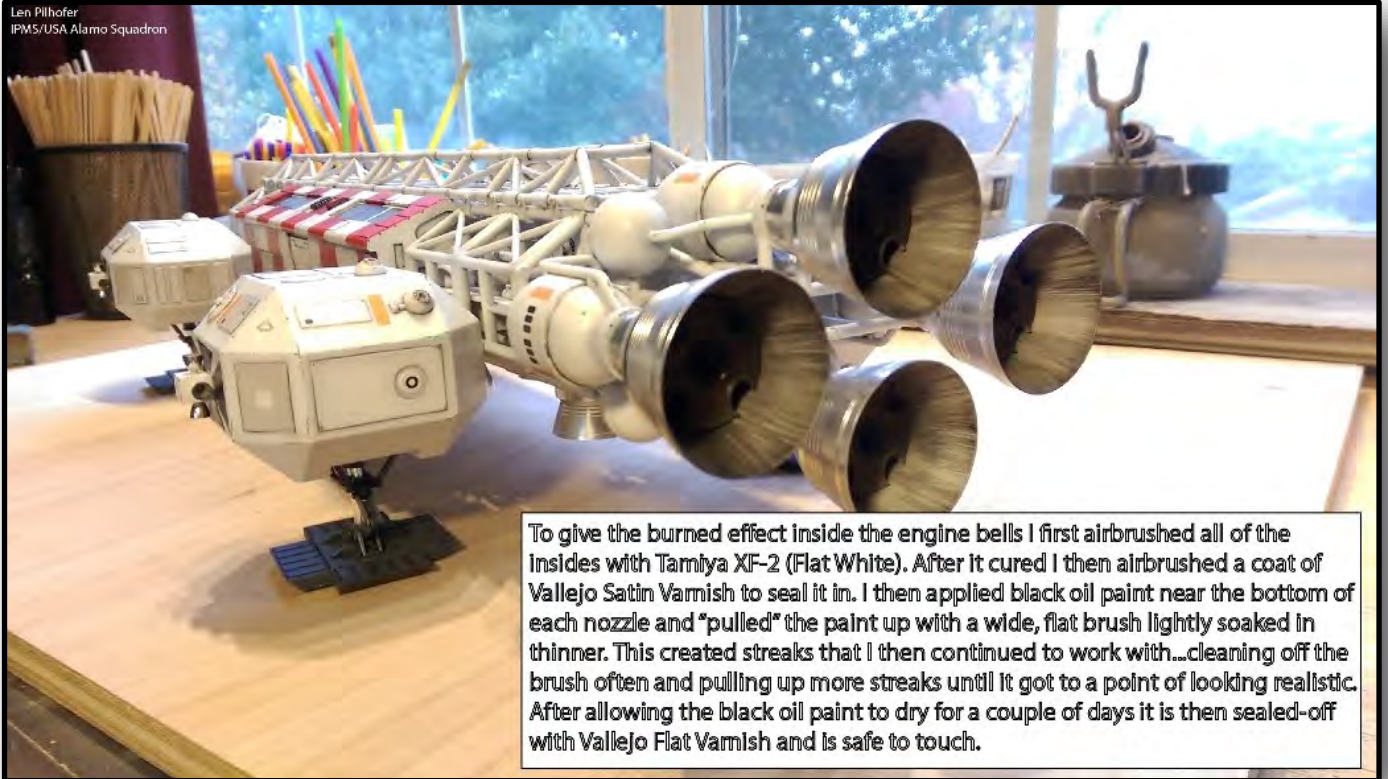

To give the burned effect inside the engine bells I first airbrushed all of the insides with Tamiya XF-2 (Flat White). After it cured I then airbrushed a coat of Vallejo Satin Varnish to seal it in. I then applied black oil paint near the bottom of each nozzle and "pulled" the paint up with a wide, flat brush lightly soaked in thinner. This created streaks that I then continued to work with...cleaning off the brush often and pulling up more streaks until it got to a point of looking realistic. After allowing the black oil paint to dry for a couple of days it is then sealed-off with Vallejo Flat Varnish and is safe to touch.

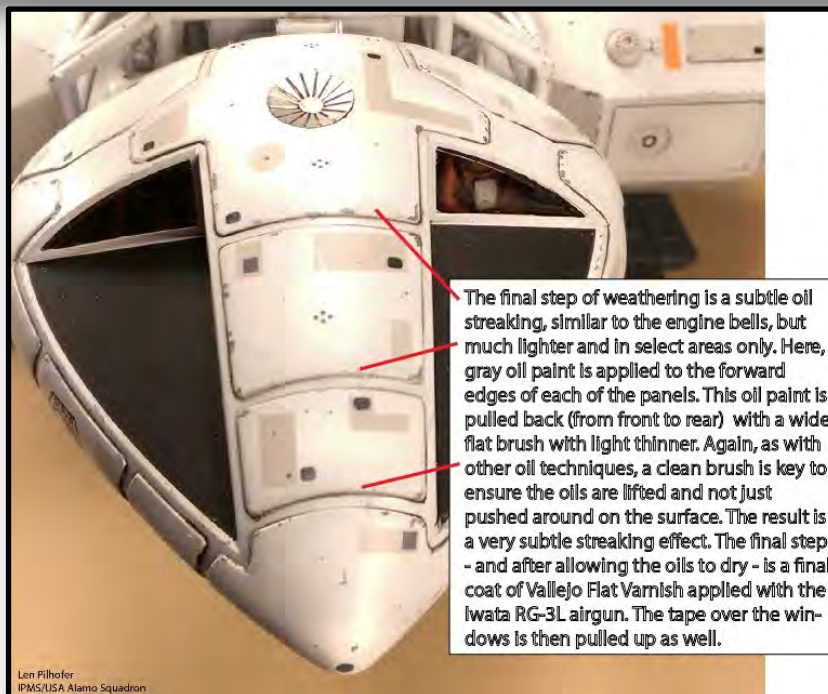

The final step of weathering is a subtle oil streaking, similar to the engine bells, but much lighter and in select areas only. Here, gray oil paint is applied to the forward edges of each of the panels. This oil paint is pulled back (from front to rear) with a wide, flat brush with light thinner. Again, as with other oil techniques, a clean brush is key to ensure the oils are lifted and not just pushed around on the surface. The result is a very subtle streaking effect. The final step - and after allowing the oils to dry - is a final coat of Vallejo Flat Varnish applied with the Iwata RG-3L airgun. The tape over the windows is then pulled up as well.

Len Pilhofer  
IPMS/USA Alamo Squadron

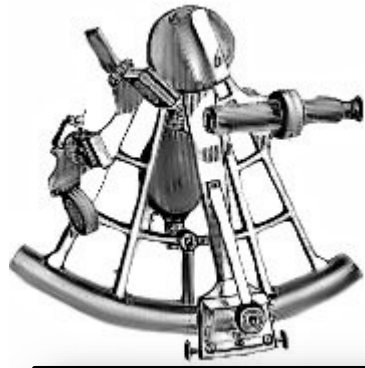

# Cover Story

---

## Weathering The Eagle

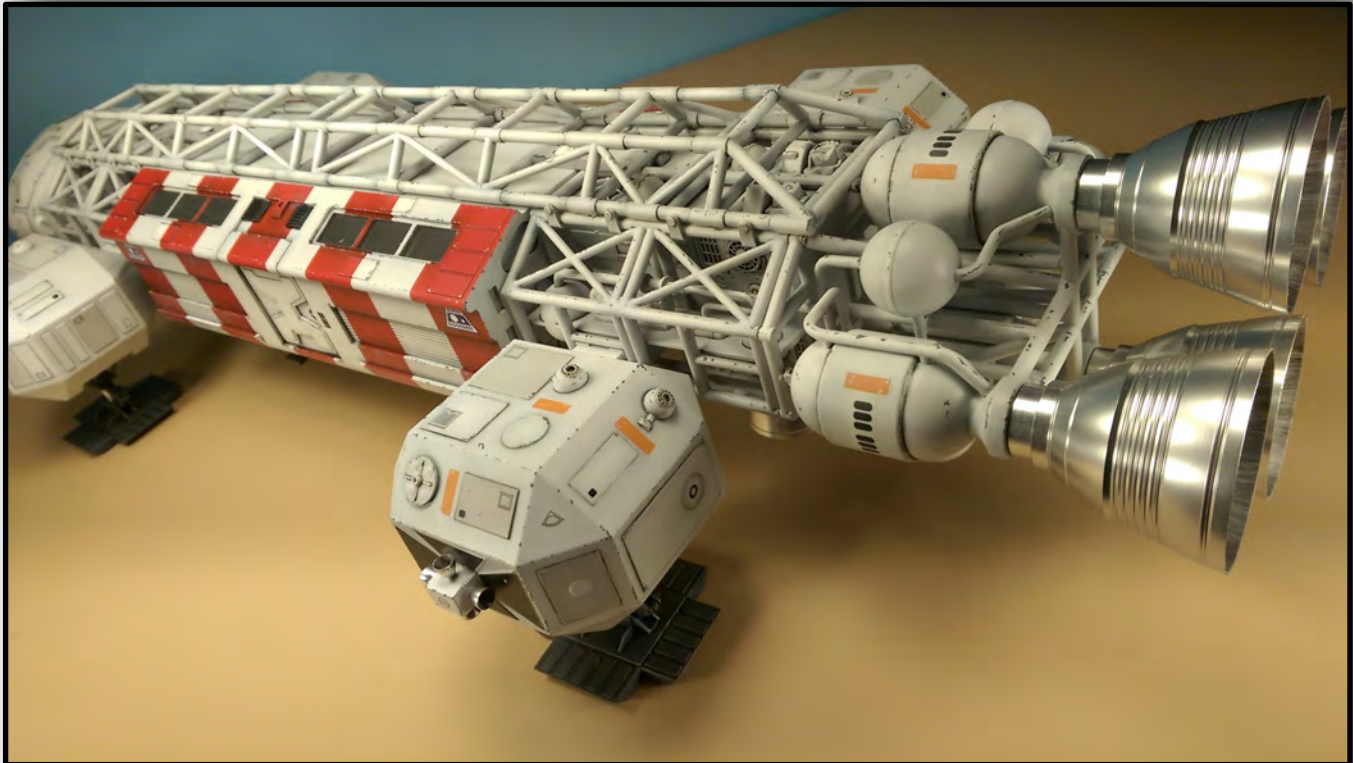
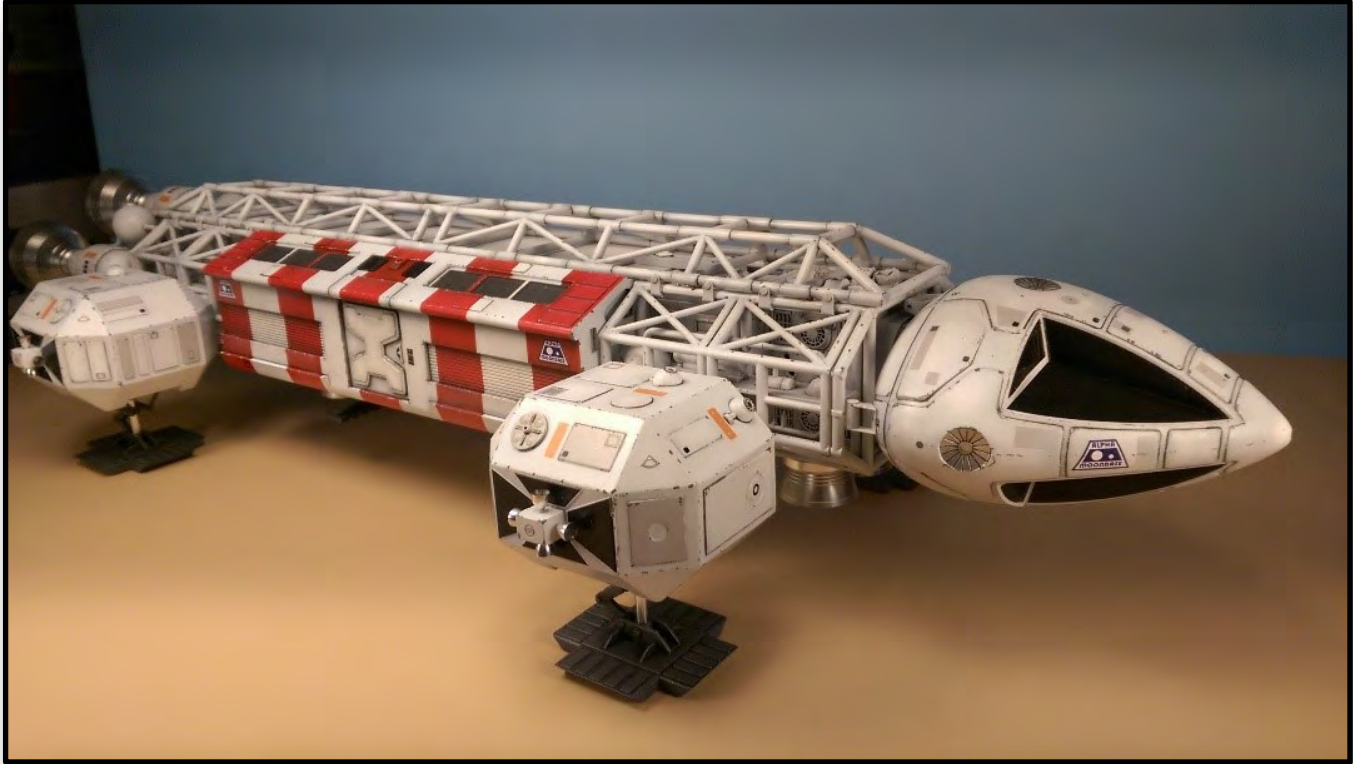

# Feature Story

## Spring 2018 Adult Build Course

Story and Photos by Craig Gregory  
IPMS# 49320

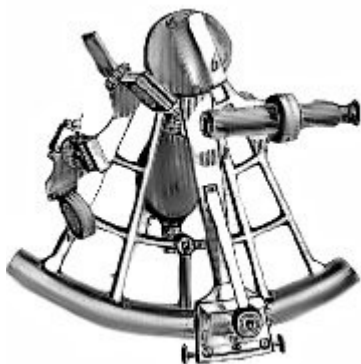

**F**rom March 3<sup>rd</sup> thru March 24<sup>th</sup> Alamo Squadron hosted the Spring 2018 Adult Building Course. The Spring ABC course is timed to follow closely behind ModelFiesta. And since I had limited time before leaving for China, a modified ABC class was needed; this ABC would be an airbrushing clinic. The class would cover airbrush basics, pre-shading, painting, filters and oil washes. Revell's Imperial Star Destroyer kit was chosen because it is a SnapTite kit; allowing the maximum amount of class time to be devoted to airbrushing.

There were 2 pre-registered participants on the first day of class. However; the class was held in the community room at Hobbytown USA and there were various walk-ins. One walk-in in particular really took an interest and joined our club. Because this ABC was not about gluing and seem repair, Len Pilhofer worked one-on-one with a modeler just starting out in the hobby. I worked with the other students building and painting the Imperial Star Destroyer.

Known as The Mobile Modeler, it was no trouble to haul my paint booth and compressor to each session. I supplied squares of styrene so that each participant was able to practice and become comfortable with an airbrush before apply paint to their model.

Each ABC is different because of the people who are either students or those that volunteer to help out. This was the most enjoyable ABC so far for me. I want to thank Len for assisting during all the sessions and providing his invaluable knowledge on airbrushing.

Learn Plastic Modeling  
**Adult Building Course**

IPMS/USA Alamo Squadron hosts the Spring 2018 ABC class. The Adult Building Course teaches basic plastic modeling skills and techniques through demonstrations while participants build the course project.



Spring 2018 Project - Revell's Imperial Star Destroyer

This ABC series will emphasize airbrushing. During the 4 week course, participants will build Revell's Imperial Star Destroyer, correct a few kit flaws and use an airbrush to paint the model and highlight surface detail.

**Dates:** Saturday's March 3rd, 10th, 17th and 24th  
**Time:** 10:30am thru 12:30pm  
**Location:** Hobbytown USA, 2501 NW Loop 410  
**Web Site:** [AlamoSquadron.com/build-class.html](http://AlamoSquadron.com/build-class.html)

**ABC Coordinator:**  
Craig Gregory  
[LearnModelling@AlamoSquadron.com](mailto:LearnModelling@AlamoSquadron.com)  
541-377-1888



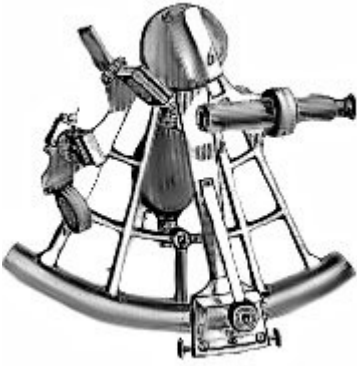

# Feature Story

## Spring 2018 Adult Build Course

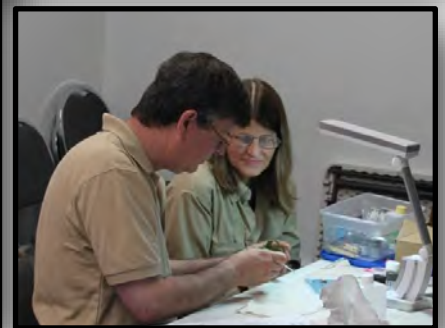

# Feature Story

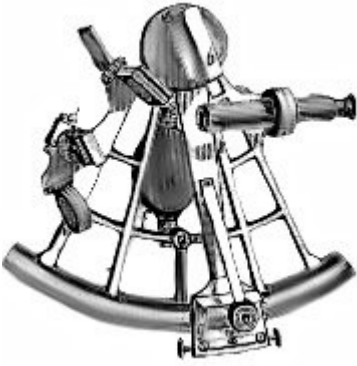

## Imperial Star Destroyer

Model and Photos By Craig Gregory  
IPMS/USA # 49320



**R**evell's Imperial Star Destroyer (kit# 85-1638) has a decent amount of detail and is loaded with fun. This kit was used as the class project in the most recent ABC course. It is a SnapTite kit which means a quick build and little time before wasted before painting and finishing starts. Taken for what it is (a SnapTite aimed at young modelers), it builds to a descent size, has plenty of surface detail and dominates my shelf of 1/144 fighters. I almost forgot to mention the build in sound and lighted main engines.

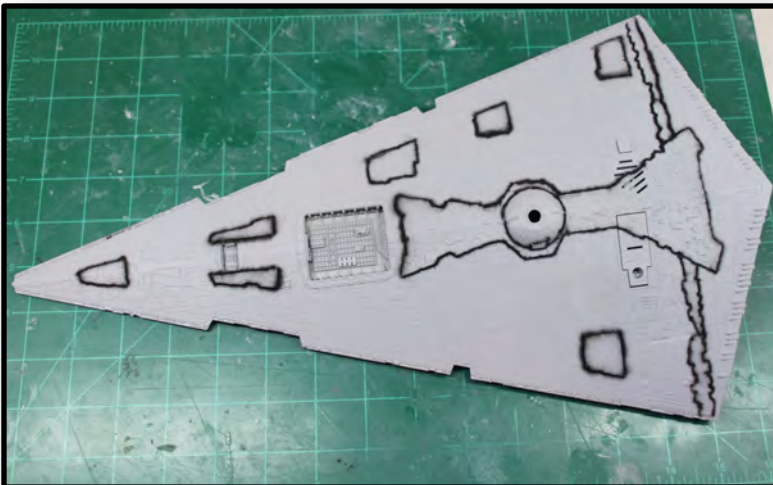

The only fault I have with the kit is the “toyish” retractable landing legs used when displaying the model. They were immediately glued in the retracted position and the seams filled.

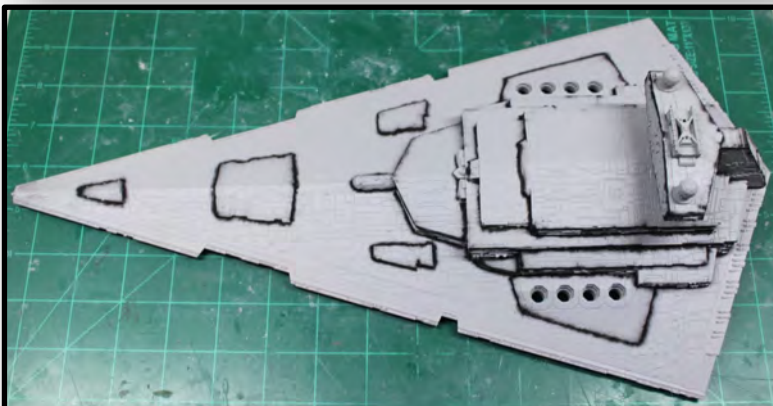
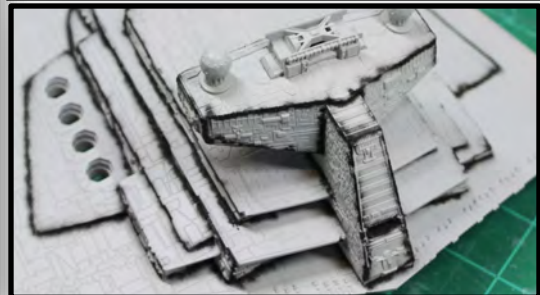

The model was built in 2 sections (top and bottom) until the end of the build.

Tamiya spray primer was applied, followed by pre-shading. Any vertical relief on the model was pre-shaded with Tamiya XF-1

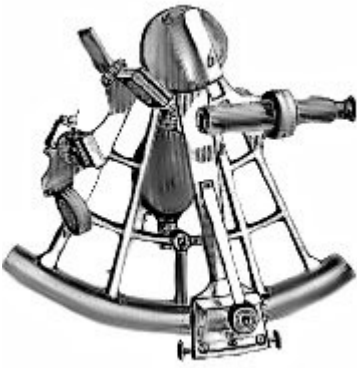

# Feature Story

## Imperial Star Destroyer

The base color is a mix of Tamiya XF-1 and XF-19. Begin by knocking down the pre-shading and cleaning up any over-spray.

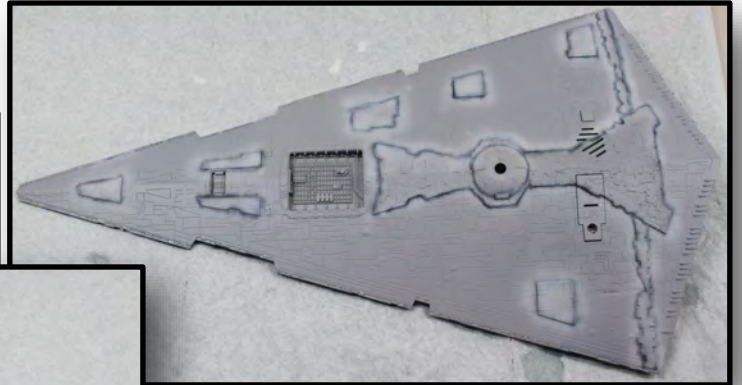

A Badger xxx single-action airbrush was used to apply the pre-shading. A Badger yyy dual-action was used to clean-up the pre-shading.

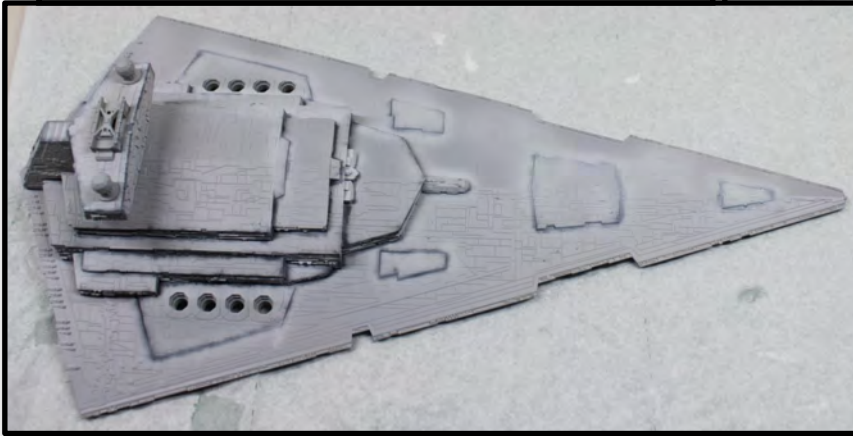

An Iwata RG-3L air gun was used to apply the base color. The goal is not a homogenous finish, but allow hints of the pre-shading and irregularities in the base coat to show through.

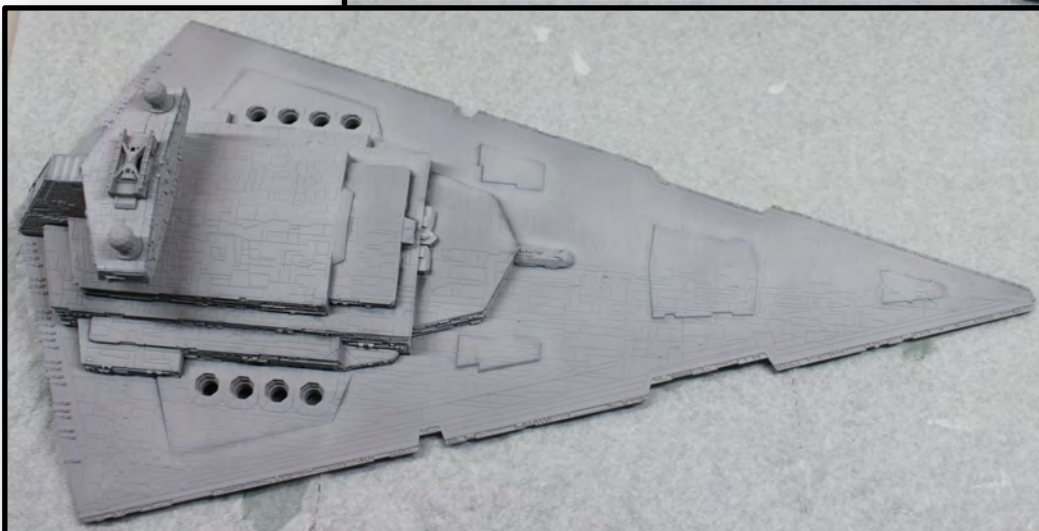
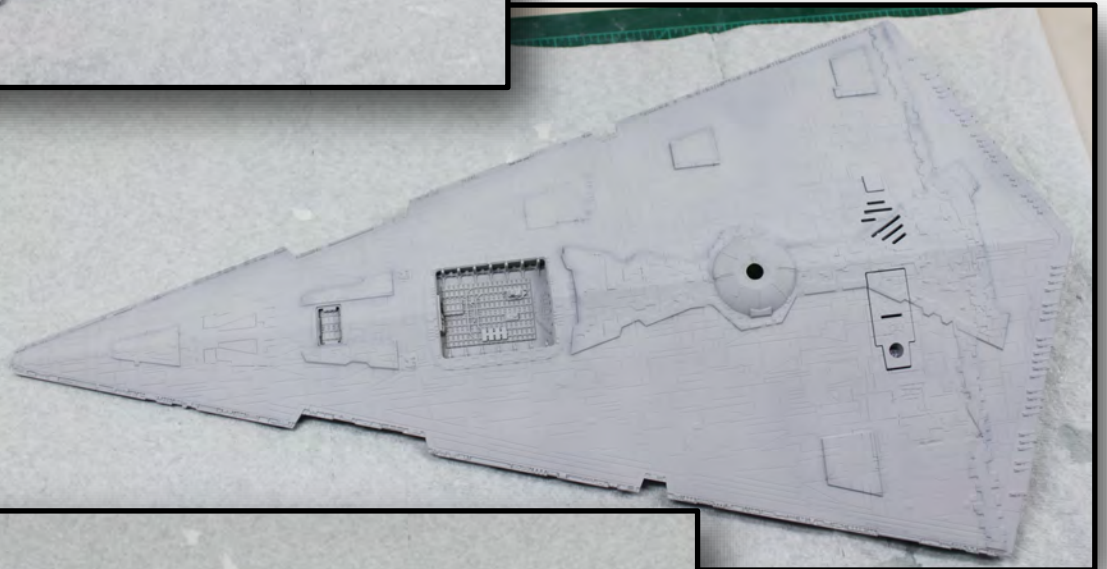

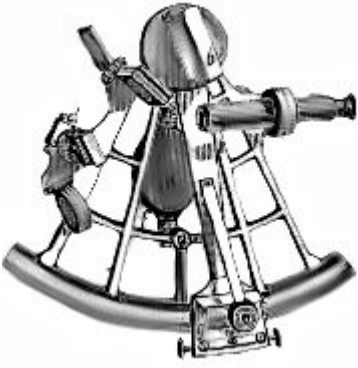

# Feature Story

## Imperial Star Destroyer

To add more texture, random areas of the surface are masked and airbrushed with Tamiya XF-19.

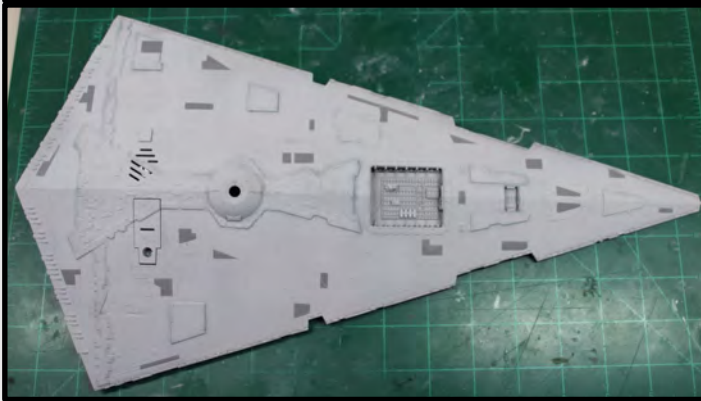
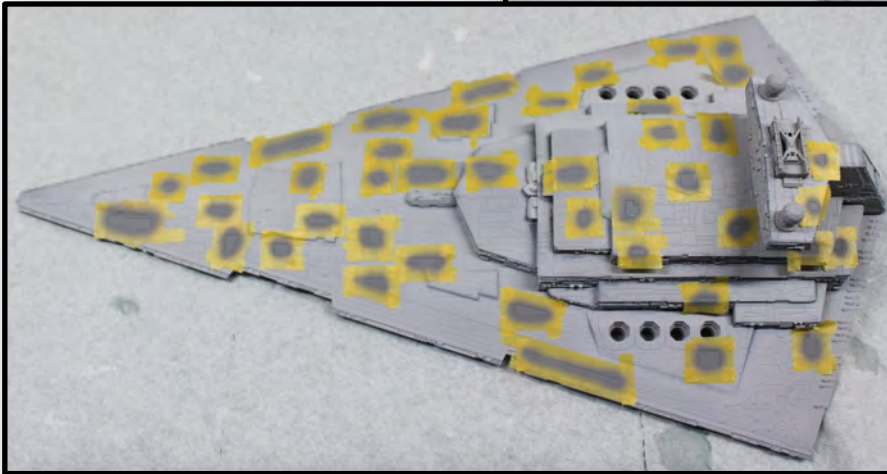
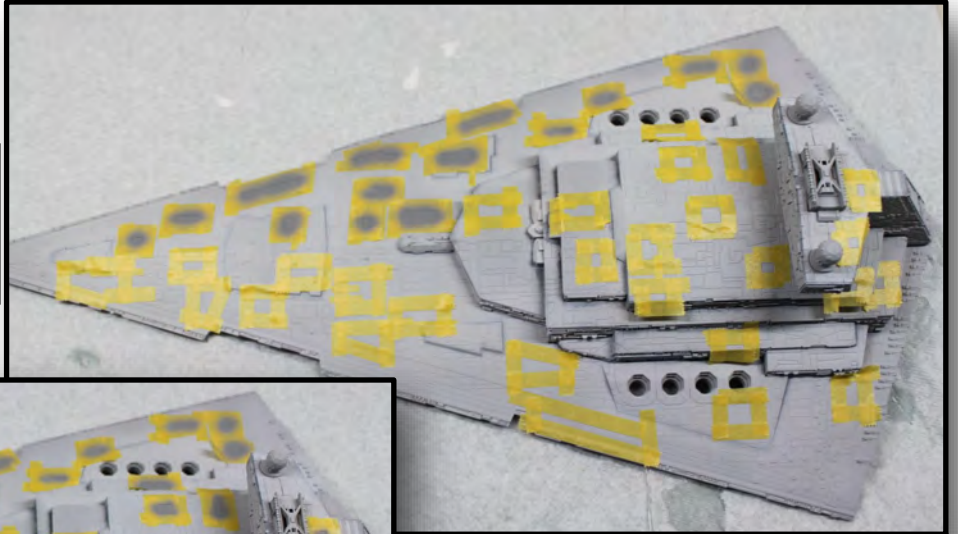

Random areas are masked off; be careful not to mask identical panels in the left and right side. A non-symmetrical pattern is the goal where more smaller colored panels are desirable over fewer larger panels.

The model may look a little stark at this point. Later, “filter” coats will tie the patch-work together.

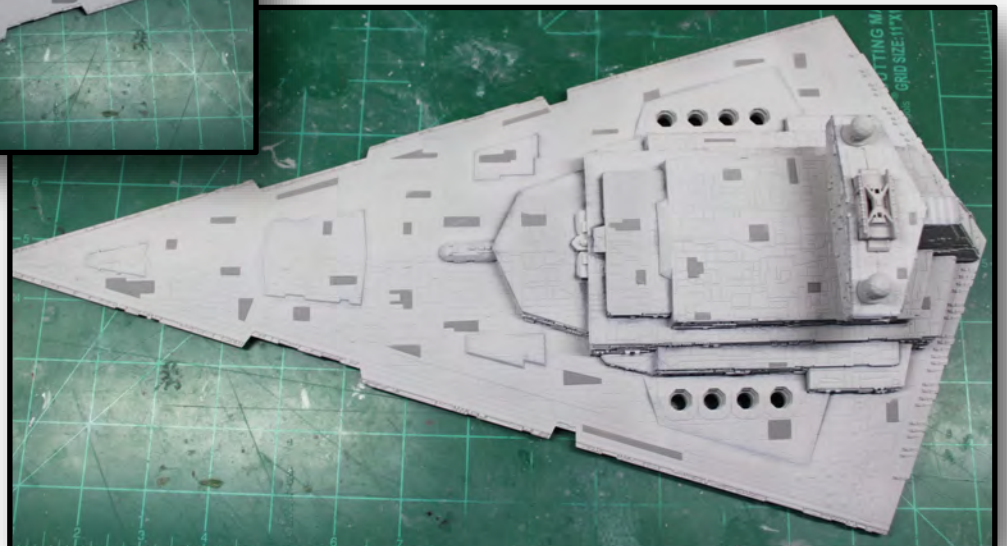



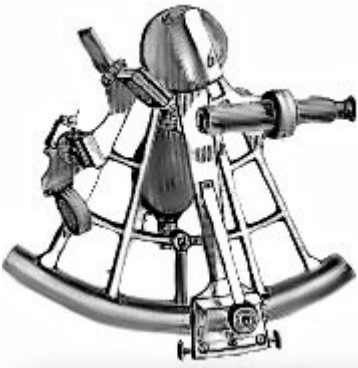

# Feature Story

---

## Imperial Star Destroyer

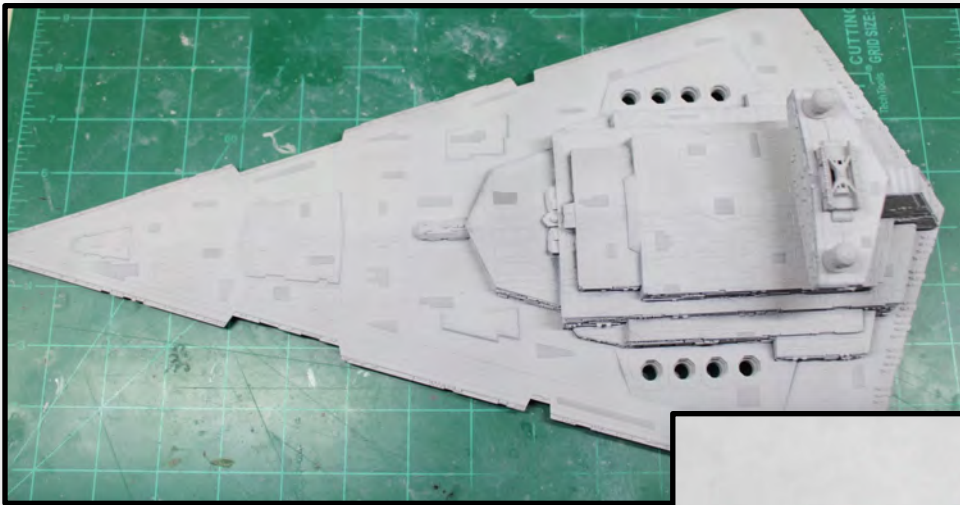

The original base color is thinned (greater than 50% thinner) further to create a “filter”. Light coats are applied until the highlighted panels blend in with the overall base color. Apply very light coats, and add others if necessary.

A dark wash (Abteilung 502’s Starship Filth) was used on the engines and turbo-cannons. Areas of the bridge were also hit.



A small amount of nose weight is added to balance the model on Round 2’s Large Dome Base. The model is heavy and weight was added under the dome base.

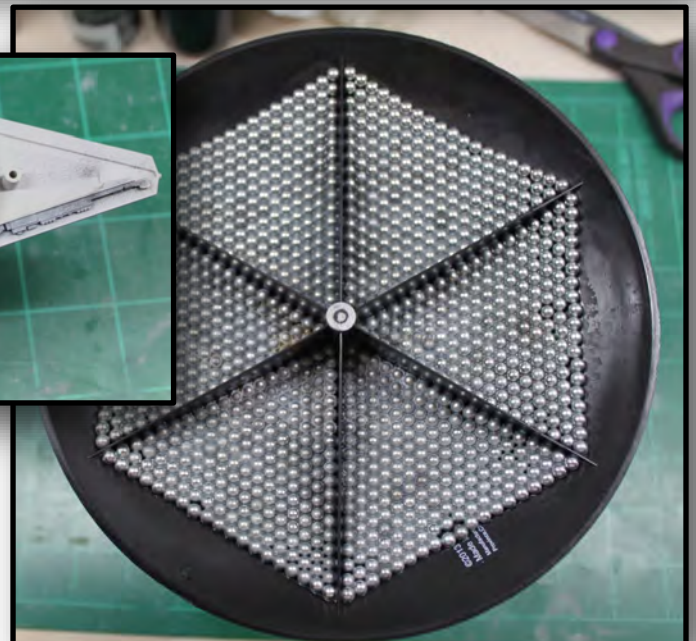

# Feature Story

## Imperial Star Destroyer

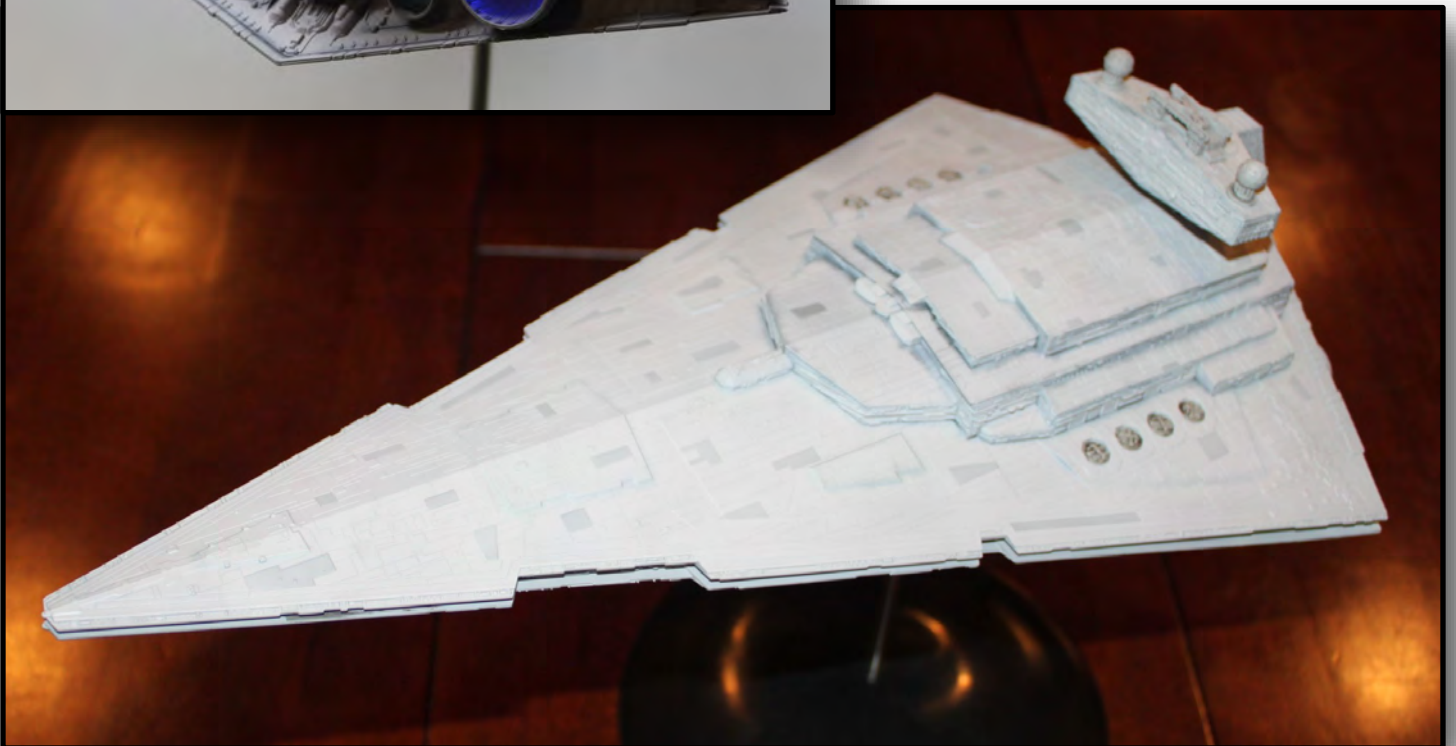
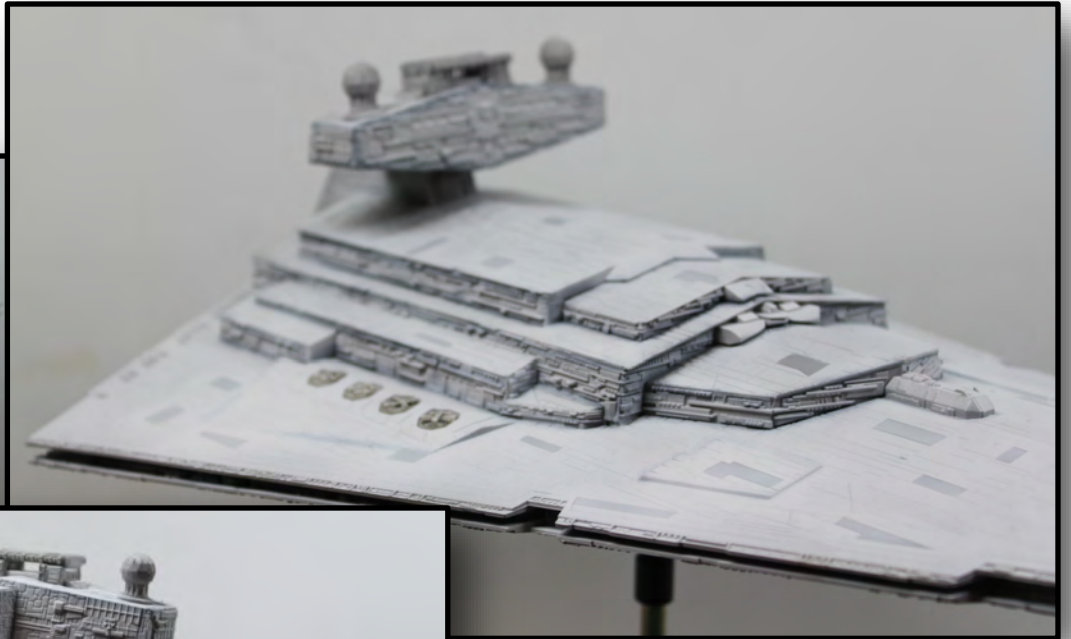
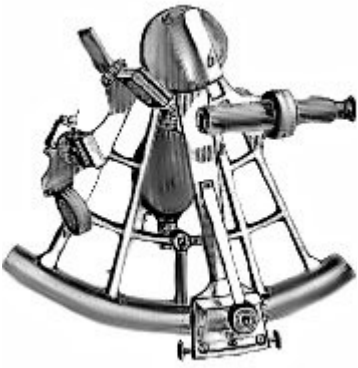

# Feature Story

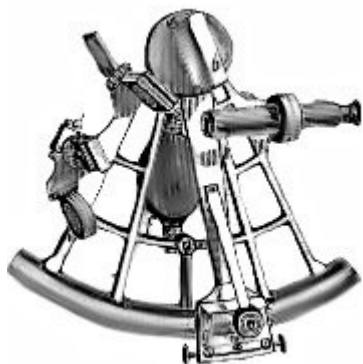

## History of Alamo Squadron

by Dick Montgomery  
IPMS # 14003



In previous articles in this journey through the history of Alamo Squadron, we focused on the first few years of the San Antonio Modelers Society, better known as SAMS. We saw SAMS organized as the 1<sup>st</sup> plastic modeling club in San Antonio, and we saw that SAMS had an official publication known as “The Modelist”. That publication was not a newsletter but was actually a “modeling magazine” with kit reviews, articles featuring a variety of modeling subjects, and accompanied by illustrations and artwork. It is not an exaggeration to say that “The Modelist” was a scholarly publication for serious modelers.

We have also seen that SAMS began to experience problems which would be familiar to many modeling clubs. There was an established core of contributors to “The Modelist”, and for the duration of the publication of “The Modelist”, contributions were submitted by the same handful of individuals. We also have seen that leadership of the club, itself, was held by the same group of individuals through the history of the club. This cadre of leaders often invited the membership to contribute and participate, but it appears that those invitations did not achieve their goal.

In this article, we will continue to trace the history of SAMS, and, as you have already seen in other articles about SAMS, it ends with a rather quiet shrug of the shoulders.

### Vol 2 Nbr 1 Jan-Feb 1971 “The SAMS Modellist”

We pick up our research in January 1971 with Vol 2 Nbr 1 “1971-01-02-Jan-Feb 1971 issue. The President of SAMS was Phil Friddell and the editor of The Modelist was Greg Ripps. Contributing writers for the January issue were Bob Angel, Frank Emmett, Phil Friddell, Vance Holliday and Don Morgan. As with issues from the previous year the Editor’s column shows some exasperation with the membership for not

submitting any content, and as the editor said, “*not even a want or disposal advertisement? Oh, come on!*”

The content of this issue includes:

- The Blow Torch (a repeating column written by Frank Emmett) entitled, “Lockheed’s First Jet: The F-80 (Part II)”
- “Defiant” by Bob Angel
- “The Hawker Audax” by Don Morgan

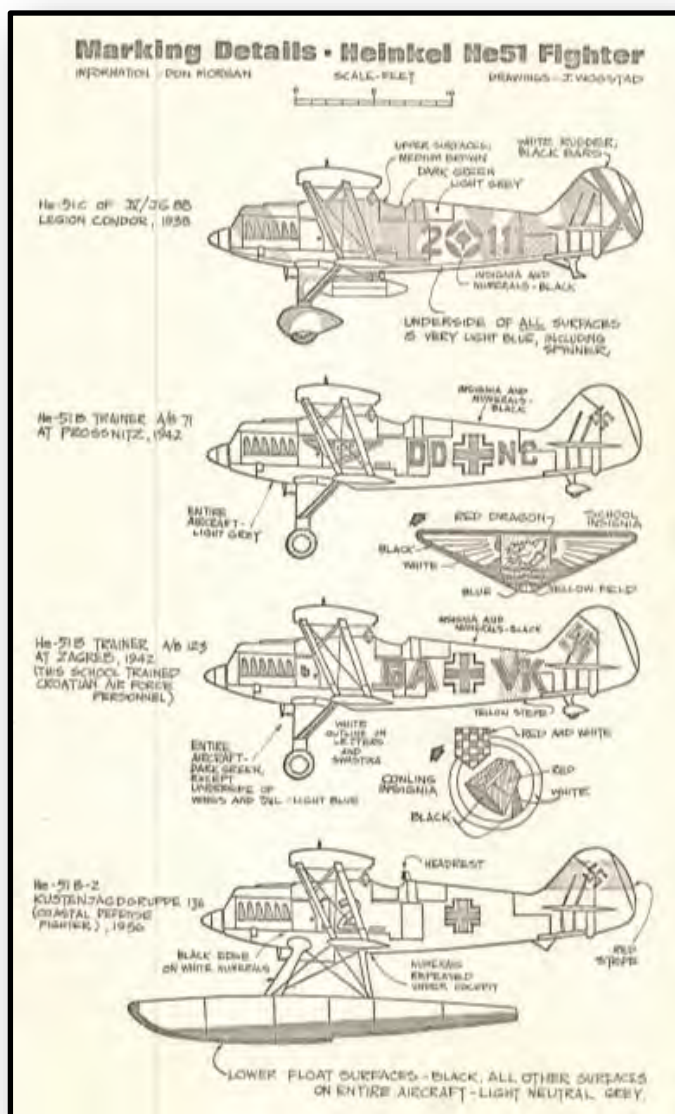

# Feature Story

---

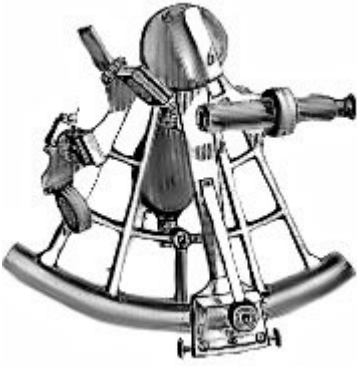

“The Old(?) Products Corner by Phil Friddell  
“The Heinkel He-51 Series” by Don Morgan  
“Junk for Tanks” by Vance Holliday  
“The Hawker Typhoon” by Phil Friddell  
“The Messerschmitt Bf-109B” by Don Morgan  
“Armor Review” by Vance Holliday in which he reviews a number of armor kits

Lastly, the editor provided a list of articles, contained in the first six issues of “The Modelist”.

It is important to remember that articles in “The Modelist” often ended with an impressive bibliography. Much effort was made to make “The Modelist” a professional publication and that effort is clearly visible.

## **Vol 2 Nbr 2- Mar-Apr ‘71 “The SAMS Modellist”**

The President of SAMS is identified in this issue as Jerry Mohr. Greg Ripps is identified as the Editor, while Bob Angel and Phil Friddell are listed as Contributing Editors. The publication artist is James Wogstad and contributors to this issue are Vance Holliday and Don Morgan.

This issue is of interest for a number of reasons, being that it represents a major change for SAMS. First and foremost, Phil Friddell announced that it was time for him to step away as the President of SAMS. Phil provided a little historical background in his column. He states that he served as the club Secretary for a year and then as President for two years. Since this newsletter is dated as Mar-Apr of 1971, that would indicate that Phil had served as Secretary for SAMS in its inaugural year and then as President. It is in this same column that Phil credits Frank Emmett as the Founder of SAMS. Phil also credited several other members for their positive contributions to SAMS. These members, identified by Phil, were Bob Angel, Greg Ripps, John De La Garza, Mike Salyers, as well as Mr. and Mrs.

Ray Johnson, who owned Dibbles Hobby Shop.

Phil also indicated that there were a number of reasons for what he called his “abdication”. Phil stated that, perhaps, his “individualism”, as he labeled it, was making things difficult for the club. Phil noted that his shoulder-length hair was off-putting to the military personnel with which the club interacted from time to time. (Remember, this was 1970-1971!). More significantly, Phil stated that due to his leadership role in SAMS during its early days, his fingerprint, as it were, covered the “policies and statutes” and that it was “time for a change”.

Phil’s column was immediately followed by a column contributed by the new President, a gentleman named Jerry Mohr. Jerry’s “inaugural speech” provided some detail about his modeling background followed by a call to members to attend meetings and to volunteer their time, to get involved in club projects, and to feel free to “speak up”.

On a personal note, one of my “Ten Commandments for Club Leaders” may have originated with Phil. That Commandment is “No Club Member shall hold an office for more than a few years.” I agree with Phil’s philosophy that a change in leadership prevents stagnation and can set the stage for club growth. Another personal connection to this issue is that, in the distant future from the “present” in which this issue of the Modelist (that “present” being 1971) some 37 years later, I was called upon by Jerry’s widow to dispose of the remaining items in his model stash. His stash filled a 10x12 storage room in a Self-Storage facility. After a few round trips and after inventorying the stash, a number of Alamo Squadron members bought some of the items, and to my knowledge, still have them. The disposal of Jerry’s modeling estate took place in the first few months of 2008 although his passing took

# Feature Story

---

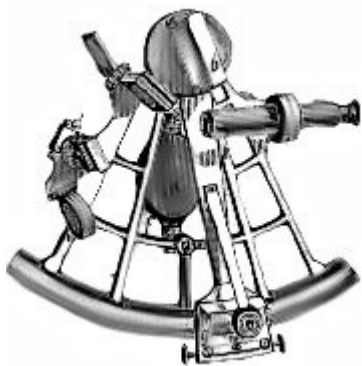

place some years prior.

The remainder of this issue featured the following articles:

- The Do-217 by Bob Angel
- The PZL P-24 by Don Morgan
- The Airmodel Conversion Kit by Phil Friddell
- New Kit Reviews by Phil Friddell
- Crusader I by Vance Holliday
- The Sopwith Pup by Greg Ripps
- Oldies But Goodies—Reviews of Older Kits Worth Building by Bob Angel
- The Curtiss Haw F6C-4 by Don Morgan
- Flares and Tracers by the Editors (A catch-all column containing general comments)

## **Vol 2 Nbr 3 May-Jun '71 “The SAMS Modellist”**

This issue was the first in which the publication title included the club name, that being abbreviated as “SAMS”. It appears that the name-change for the publication had not yet reached into all areas of the document. The cover of this issue used “The SAMS Modellist” and yet, the mast head on page 1 referred to the publication in the “traditional” verbiage, using “The Modellist. We will make short order of this issue since there is little information about SAMS within.

The President is Jerry Mohr, the Editor is Greg Ripps, the artist is James Wogstad and contributing editors are Bob Angel and Philip Friddell. Contributors to this issue are Vance Holliday, Michael McMurtrey, Jerry Mohr, and Don Morgan. While McMurtrey is a new name in the list of contributors, it is noted that while Friddell had stepped away from the Presidency, he continued to make contributions to the publication. By the way, as of this writing, Mike McMurtrey has long been a resident of the Dallas area and still involved in modeling.

A quick listing of the contents will be sufficient for this issue, and that content is:

- The Ultimate in One-Up-Manship-The Rareplane by Phil Friddell
- Israeli Armor: The Six Day War (Part 1) by Vance Holliday
- The Westland Wallace, Mk. I by Don Morgan
- A Catalogue of Decals for Marking the Luftwaffe by Jerry Mohr
- An Odd Couple from Westland by Bob Angel
- Cerro-Safe: A Tricycle Blessing by Phil Friddell
- New Kits Review by Phil Friddell
- The Wind tunnel by Mike McMurtrey
- New Armor Kits by Vance Holliday
- The Old Kits Review by Phil Friddell

## **Vol 2 Nbr 4 July-Aug 1971 “The SAMS Modellist”**

In Vol 2 Nbr 4 issue of “The SAMS Modellist”, we see some cracks in the SAMS foundation. Editor Greg Ripps offers an explanation as to the quality of the publication by stating that the grade of paper used to print the issue was not sufficient to allow printing on both sides of the paper while preventing “bleed-through” of the text. To the reader, it was, most likely, overlooked, but to Mr. Ripps, who made every effort to maintain the quality of the publication, it was a disappointment.

In his “President’s Column”, Jerry Mohr picks up on the nature of the changes that impacted “The SAMS Modellist”. Mohr explained that the staff was unexpectedly impacted by the departure of “a few of the major contributors and staff” of the publication. No names were listed, however it was noted that the names of some regular contributors to “The Modellist” were not present in this issue. Three names stood out as missing, those being James Wogstad, who had been

# Feature Story

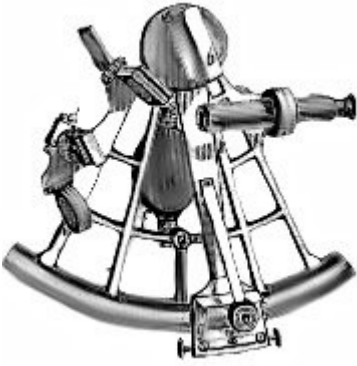

listed repeatedly as “Artist”, Frank Emmett, and Phil Friddell. President Mohr’s column went on to state that “a few of the major contributors and staff “had moved on to a private venture.” It should be recognized that those who have provided their time, treasure, and talent to the publication of “The Modelist” had a major role to play in making “The Modelist” a “high quality” publication. Because the names were not listed as contributors to this particular issue of “The Modelist” does not confirm that it was Wogstad and Emmett (and others) who departed for greener pastures.

The contents of this issue are shown in the Table of Contents as:

- Israeli Armor: The Six-Day War (Part II) by Vance Holliday
- The Mitsubishi 1MD1 by Don Morgan
- “Random Notes with a French Accent by Bob Angel
- “Flares and Tracers”- a column for random thoughts

## Vol 2 Nbrs 5/6 Sep-Dec ‘71 “The SAMS Modellist”

This issue (Sept-Dec 1971) begins with what is believed to be an error. Phil Friddell, who had “abdicated” as President in the March-April issue of “The Modelist” is listed as President once again. There is no mention of President Jerry Mohr stepping down, or of an intervening election returning Friddell to office, so it is assumed that he was mistakenly listed as the President in this issue. Further, there is no “President’s Column” in this issue, by either Friddell or Mohr.

The Editor, Greg Ripps, posted an Editor’s Column in which he submitted his resignation as Editor of “The Modelist”. In his column he included wording that in-

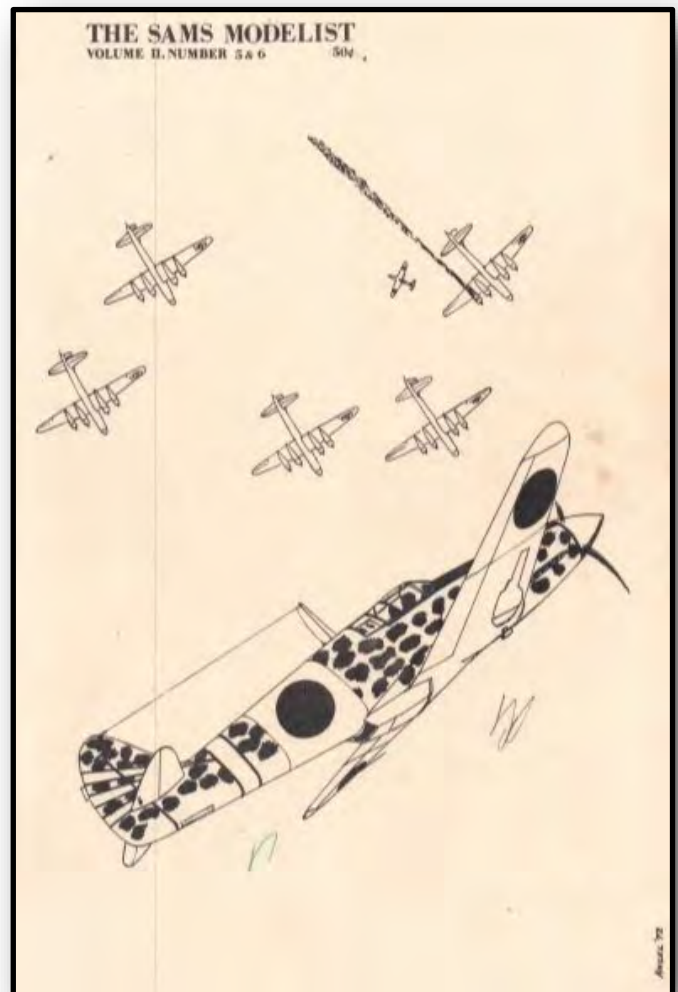

dictated that he had been assured that “The Modelist” would continue to be published, and the assumption is that the regular contributors would step up to make sure the publications would continue to be printed.

The articles in this issue are listed as:

- The 1/72 Bubbletop “Jug-Improved” by Jim Dungan
- The Stopgap Mureaux by Bob Angel
- The Bristol Fighter by Dan Waelti
- Some Thought on a P-35 by Don Morgan
- IPMS Publication Survey by Hugh R. Muir

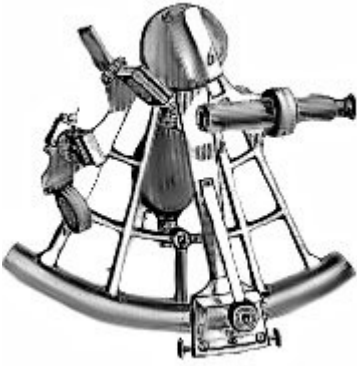

Notes on the Barracuda by Bob Angel

## Summary-

The Vol 2 Nbrs 5 & 6 Sept – Dec 1971 issue of “The Modelist” is the last issue that is on file in the section of the Alamo Squadron archive that stores information about SAMS. Between this issue, dated Sept-Dec 1971, and the end of SAMS as described by Bob Angel in the following paragraphs, it is assumed that either the production of “The Modelist” ended, or that no copies of the publications have been recovered for the Alamo Squadron archives.

## The End of SAMS

Printed in a previous issue of the “Navigator” Bob Angel described the end of SAMS in this manner:

“By the early 70’s we had use of the NCO club for club meetings, largely due to Tom Ward’s efforts. A “Super Contest” was scheduled there in July 1974 and I was in charge of planning and trophies. When the morning arrived very few members were arriving. We had awards and judges in place and very little was happening. Finally, we had to get started, the judges were finished very quickly, and as it turned out, we had more trophies available than the total # of models! Every model got a trophy and the leftover ones were given to each judge as a token of appreciation. Well, there were some unhappy contestants and there were others who didn’t seem the least bit bothered. It seemed the club had run its course due to an overall lack of interest.” Bob A continues, “The final SAMS meeting was circa August 1974. The treasury (always in cash) had been nearly depleted by the lousy (ed. turnout at the) contest. It was announced that at this final meeting the cash would be divided up evenly, and the club library (a box of books that the poor librarian had to lug to each meeting) would also be par-

celed out.”

Dick Montgomery added, “*Thus was the end of SAMS. In some cases, this meeting was the last time I saw some of the SAMS members. Some of these gentlemen, I would see at Dibbles or Dick’s Hobby Shop. (Dick’s Hobby Shop was on Austin Highway in a mini-mall that was called Terrell Plaza-no relation to me.). Some would continue to meet informally and would eventually form Alamo Squadron, but that is a story for the next installment.)*”

Bob Angel became a leader in Alamo Squadron and remained active in the club until around 2001 when he retired from active participation. Bob has contributed a massive amount of documentation that forms the backbone of the SAMS and Alamo Squadron archive. Bob is a frequent flyer at ModelFiesta, running a vendor table. From time to time I have seen Phil Friddell, Lee Bracken, and Alan Larrumbide. Alan and Bob shared some vendor space at ModelFiesta 37/Region 6 Convention in February of 2018. It’s been a few years, but I saw Phil and Lee Bracken at Hill Country Hobby. These gentlemen contributed to the success of SAMS and some continued their membership in “organized modeling” in San Antonio by joining Alamo Squadron. Other SAMS members have passed away, such as Frank Garcia, and Leo Zeigler, who were there during the SAMS days and also early in the history of Alamo Squadron. It’s hard to say that some other SAMS members won’t walk through the doors at ModelFiesta in the future, and when they do, they are encouraged to let their presence be known to the Contest Registrars or the General Admission staff. It would be a great opportunity to take a few pictures and to greet them, once again, after so many years have gone by.

# Feature Story

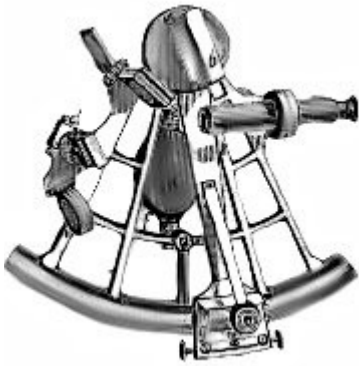

This historical coverage of SAMS will end with a list of persons who were noted as “Dues Paid” members either in notes taken by Phil Friddell, or by a listing in various issues of “The Modelist”. Clearly, in the case of some notable members (names marked with an asterisk) their membership began on an earlier date, but no records, showing a specific “join date”, exist in the archive. The date of membership shown below is, therefore, the earliest date for which there is a written record in the archive files.

Anderson, Mark	Feb 19, 1969
Angel, Bob	Nov, 1969
Bishop, Knox	Feb 19, 1969
Brower, Tommy	Nov, 1969
Burns, Fred	March 5, 1969
DeLaGarza, John	Feb 19, 1969
Emmett, Jr., Frank*	March 5, 1969
(Founder of SAMS according to Phil Friddell)	
England, Leslie	Nov, 1969
Ennis, Jim	Feb 19, 1969
Easenmacher, Sterling	Nov, 1969
Friddell, Phil*	Feb 19, 1969
Garcia, Frank	Feb 19, 1969
Gaunt, Bill	March 5, 1969
Holliday, Vance*	Nov, 1969
Jasso, James	March 5, 1969
Lucas, Jack	March 5, 1969
McClenden, Bob	Sept, 1971
Mendoza, Fernando	Nov, 1969
Montgomery, Dick	Feb 19, 1969
Mohr, Jerry	Nov, 1969
Morgan, Don*	Sept, 1971
Murphey, Griffen	March 5, 1969
Overdahl, Alfred	Nov, 1969
Ott, David	Nov, 1969
Potts, Dana	Sept, 1971

Reagan, David	Feb 19, 1969
Reif, Mike	March 5, 1969
Ripps, Greg*	Feb 19, 1969
Salyers, Mike*	Sept, 1971
Shirley, Dean	Nov, 1969
Stranford, Halbert	Feb 19, 1969
Sullivan, Charles	Sept, 1971
Tait, Ricard	Nov, 1969
Tingle, Myron	Feb 19, 1969
Todd, Bill	Nov, 1969
Waelti, Dan	Nov, 1969
Wogstad, Jim*	Sept, 1971
Ziegler, Leo	March 5, 1969

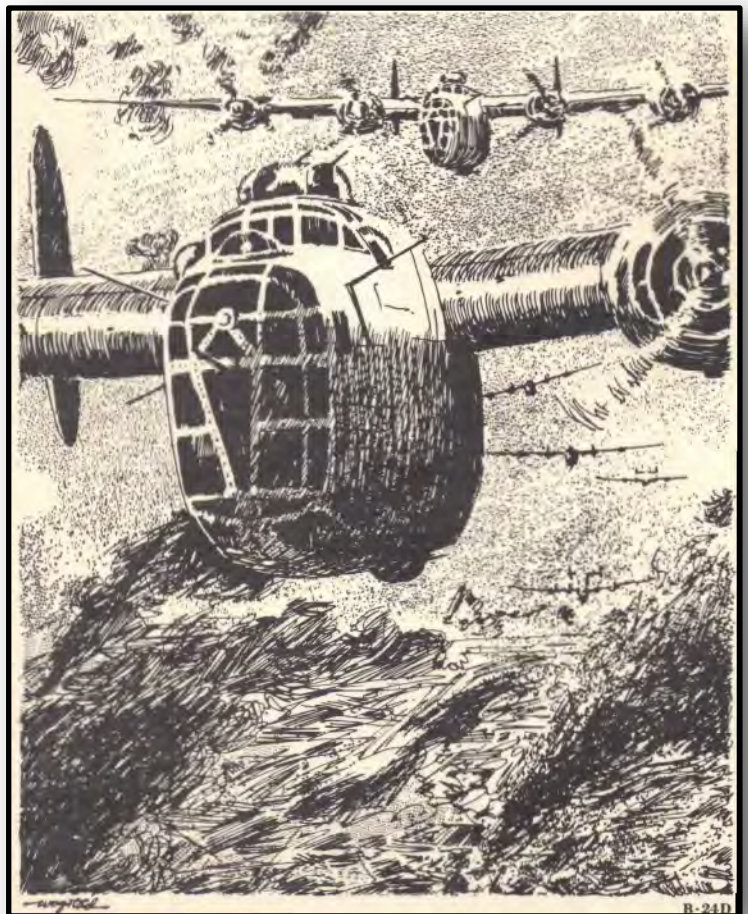



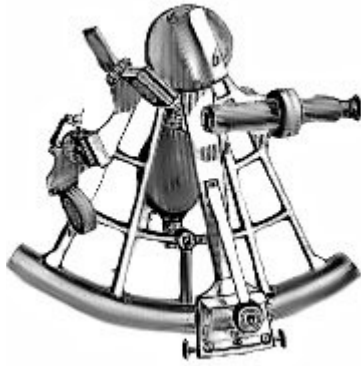

# Upcoming Events

IPMS Region 6

**Next Meeting: Thursday, May 3rd, 2018 at 7:00PM**

**Location: Northside Ford of San Antonio**

**June 2, 2018**  
**Scalefest 2018**  
**Grapevine Convention Center**  
**1209 South Main St**  
**Grapevine, TX 76051**  
<http://www.ipmsnct.net/Scalefest.htm>



**June 8, 2018**  
**SoonerCon 2018**  
**Council Road Baptist Church**  
**7903 NW 30th**  
**Bethany, OK, 73008**



**July 21, 2018**  
**HAMS Annual Model Show & Contest**  
**Cypress Creek Christian Community Center**  
**6823 Cypresswood Drive, Spring, TX 77379**  
<https://www.ipms-hams.org/annual-contest/>



**1-4 August, 2018**  
**IPMS/USA National Convention**  
**Phoenix Convention Center**  
**100 N 3rd St, Phoenix, AZ 85004**  
<http://www.ipmsusanationals2018.org>



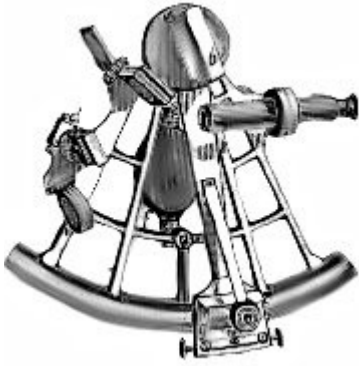

# About Alamo Squadron

---

## Executive Board 2018-2019



**President**  
**Herb Scranton III**  
IPMS #48314  
president@alamosquadron.com



**Vice President:**  
**Jose Valdenegro**  
IPMS #50490  
vp@alamosquadron.com



**Treasurer:**  
Dana Mathes  
IPMS #43781  
sec-treas@alamosquadron.com

**IPMS/USA Alamo Squadron** was founded on November 17<sup>th</sup>, 1977 in San Antonio, Texas, for the enjoyment of building scale models and the camaraderie of the members. It is a hobby-centered social organization which, at its core, is focused on scale modeling of all kinds. It is an excellent source of information for those who wish to enhance their modeling skills and improve their modeling techniques, and is open and inviting to visitors and guests. Dues are \$24.00 a year, due to the treasurer on September 1st of each year.

Alamo Squadron has been hosting ModelFiesta since 1981. Locations have included the Wonderland Mall, a Holiday Inn, the Seven Oaks Motel & Convention Center, the Live Oak Civic Center and the new location in 2013, the San Antonio Event Center.



QR Code for our Web Site  
Scan it with your cell phone's QR software to get to our web site!



QR Code for our Facebook Page  
Scan it with your cell phone's QR software to get to our home on FB

[www.alamosquadron.com](http://www.alamosquadron.com)



# Final Words ...

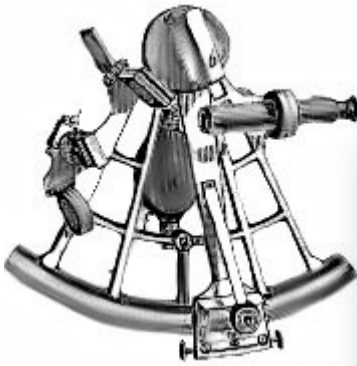

<http://www.ipmsusa.org/>

IPMS/USA MEMBERSHIP FORM			
IPMS No.:	Name: _____		
Address: _____	If Renewing	First	Middle Last
City: _____	State: _____	Zip: _____	
Phone: _____	E-mail: _____		
Signature (required by P.O.) _____			
Type of Membership	<input type="checkbox"/> Adult, 1 Year: \$30	<input type="checkbox"/> Adult, 2 Years: \$58	<input type="checkbox"/> Adult, 3 Years: \$86
<input type="checkbox"/> Junior (Under 18 Years) \$17	<input type="checkbox"/> Family, 1 Year: \$35 (Adult + \$5, One Set Journals)		How Many Cards? _____
<input type="checkbox"/> Canada & Mexico: \$35	<input type="checkbox"/> Other / Foreign: \$38 (Surfaced) Checks must be drawn on a US bank or international money order		
Payment Method: <input type="checkbox"/> Check <input type="checkbox"/> Money Order			
Chapter Affiliation, (if any): _____			
If Recommended by an IPMS Member, Please List His / Her Name and Member Number:			
Name: _____	IPMS No.: _____		
<b>IPMS/USA</b>		PO Box 56023	
Join or Renew Online at: <a href="http://www.ipmsusa.org">www.ipmsusa.org</a>		St. Petersburg, FL 33732-6023	

Alamo Squadron's newsletter, "The Navigator", is published monthly by IPMS/USA Alamo Squadron of San Antonio, for the enjoyment of the members of Alamo Squadron and its friends around the world. Articles, reviews, news items, and other hobby-related contributions are very welcome. Send text file, photos, and web sites as well as feedback to our editor, Len Pilhofer: [pilhofer@hotmail.com](mailto:pilhofer@hotmail.com)

## Support your Local Hobby Shops!

For models, paints, books, decals, tools and more!



Email: [dibbleshobbies@gmail.com](mailto:dibbleshobbies@gmail.com)

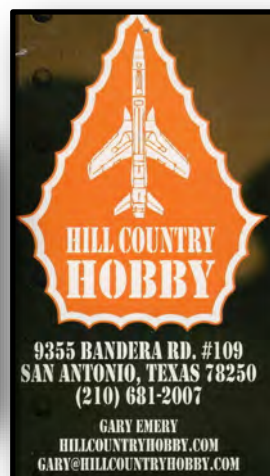

<https://www.hillcountryhobby.com>



<https://www.hobbytown.com/san-antonio-tx/l108>